

Cutting & Folding

options

Robert Heithaus
601.434.0026
rheithaus@hawkconverting.com



Half cut

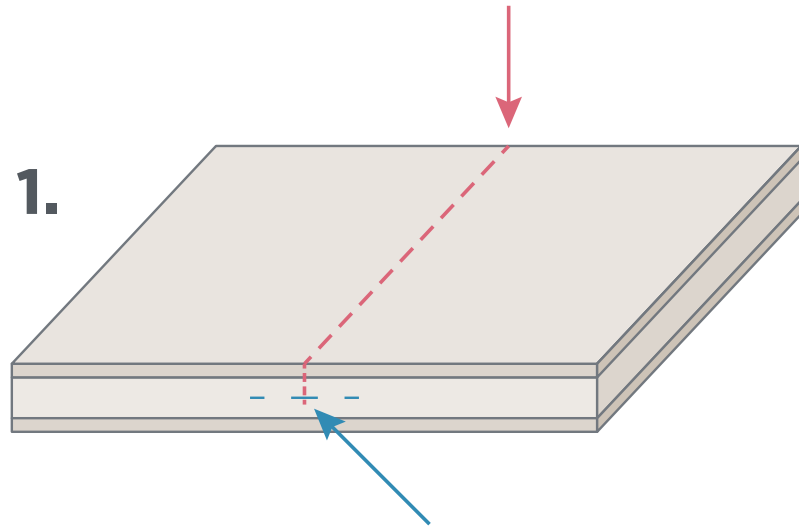

When you cut, cut beyond the middle of the board.

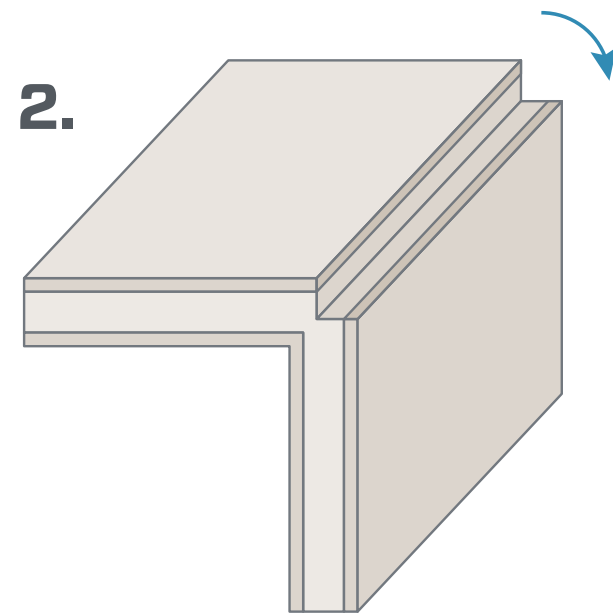

V-cut

(thick material only)

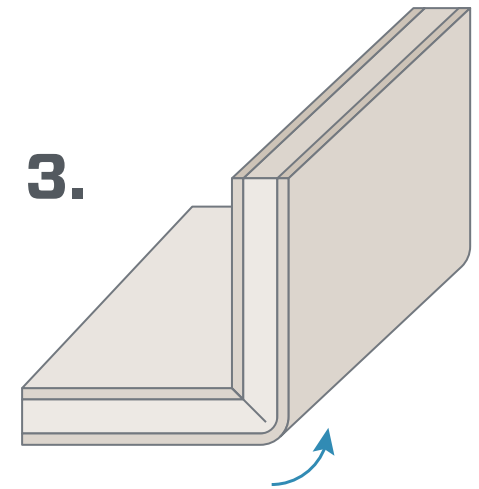
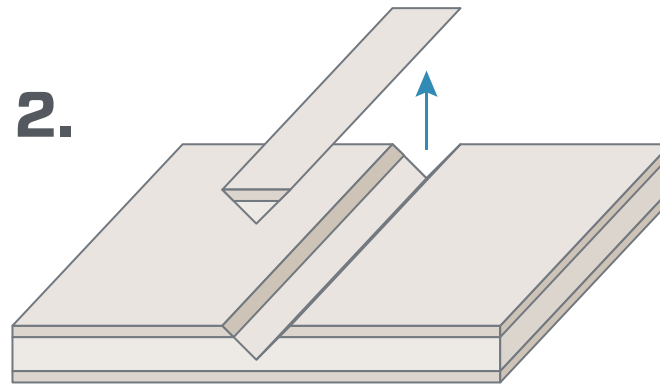
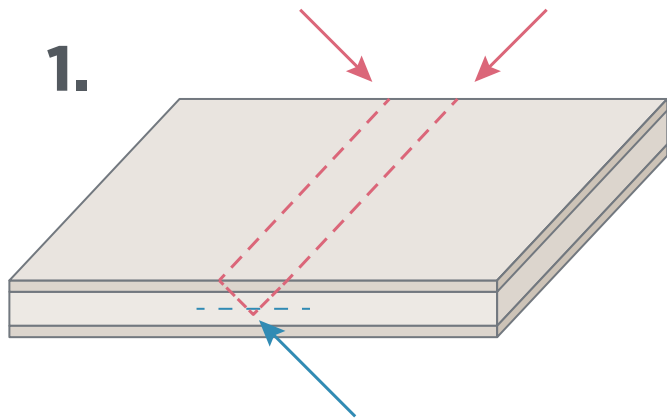

Deeper cut needed than when creating half cut. This prevents tension on the fold.

Creasing

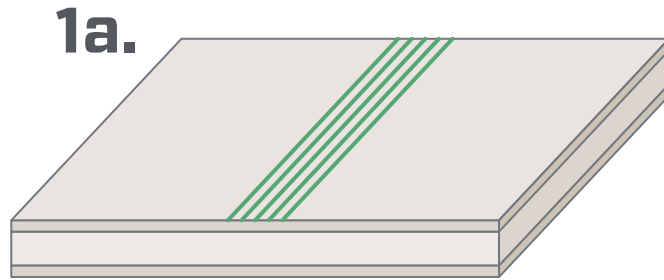

Multiple lines.

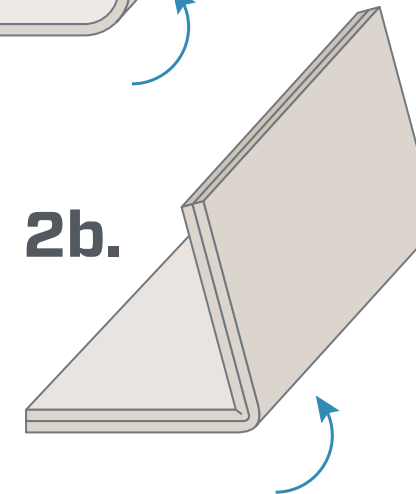
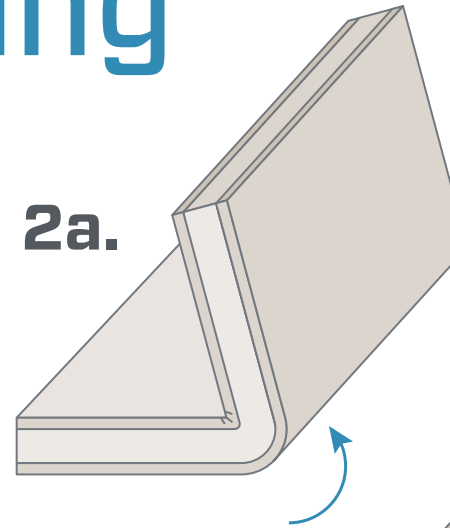
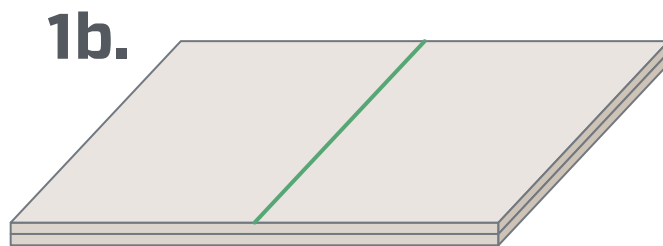

We always recommend the use of a creasing matrix.

The number of crease lines depends on the thickness of the board, the angle of the fold and equipment used to create the fold.

General rule: The thicker the material, more crease lines required.